

TECH SHEET

TRON BP

Serie



Optional



Specs

Article:	1345 BP
Number of lamps:	45 (45 low pressure body)
Single lamp power LOW PRESSURE:	21 x 230 Watt canopy / 24 x 230 Watt (bench)
Total power:	11000 Watt
Maximum hot air volume ejected:	2000 meters cube / hour
Hot air ejection:	300 mm diameter
Frequency:	50 hz
Voltage:	400 Volt three-phases
Plug:	Five Poles RST+N+T 32 Ampere
Weight:	340 kg

Features

- | | |
|---|--|
| <ul style="list-style-type: none"> • Serie / ° Optional • Graphic Display • Fan regulation 5 levels • Electronic hour counter and session counter • Coin validator interface • Token interface • Lamp protection in high UV permeability acrylic • Open system with security spring | <ul style="list-style-type: none"> • ECO • Electronic Check • Hi-Sound (Radio FM Hi-Fi) ° Breezer ° Vocal synt (speech synthesizer) ° Lightroom (LED RGB lights) ° PushPanic (automatic open and close) |
|---|--|

Dimensions

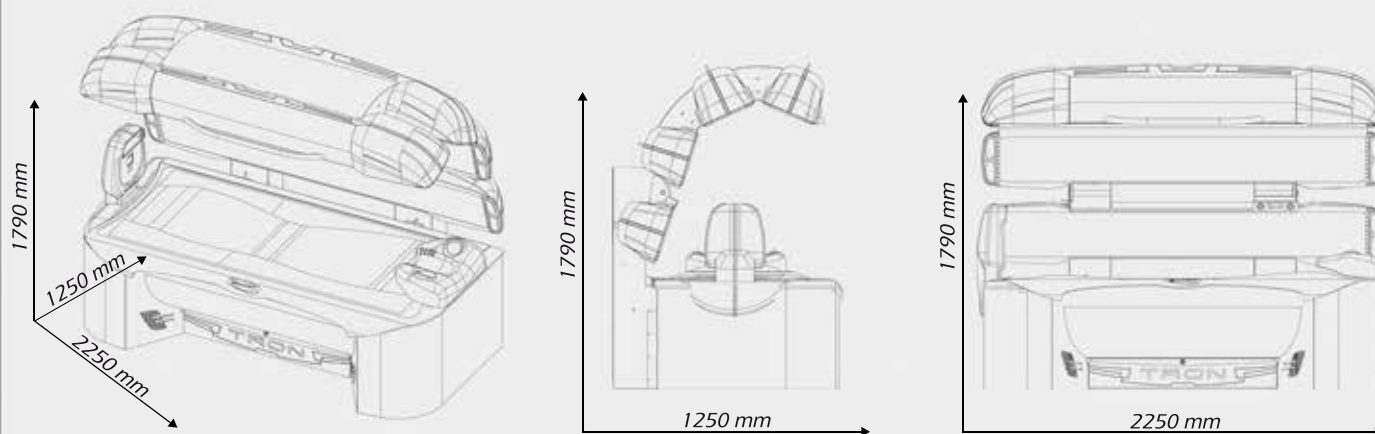

This device is accordant to CE